

x 1000 rpm	1,56 cc
x 1500 rpm	2,34 cc
Max. Continuous Pump Speed	3000 rpm
Max. Limited Pump Speed	3500 rpm
Max. Continuous Pressure	600 bar
Max. Intermit. Peak Pressure	700 bar
Weight without inlet fitting	5,50 kg
Weight with inlet fitting	5,60 kg
Fluid	Min.B.Hyd.Oil
Inlet	G 1"
Outlet	G 1/4"

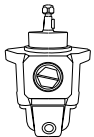

CW

Rotation :
Fixed-Clock Wise

6 cc

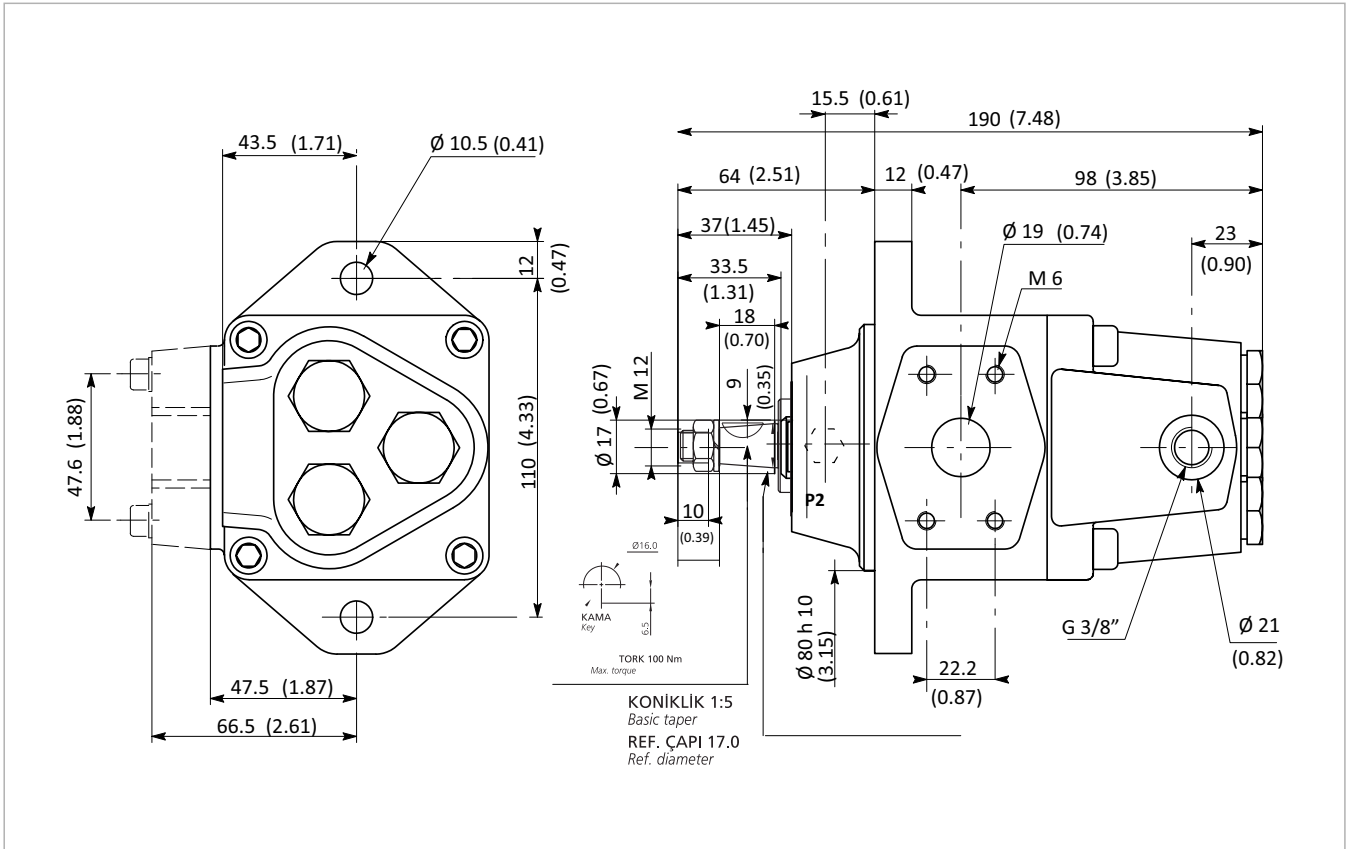

x 1000 rpm	4,40 cc
x 1500 rpm	6,60 cc
Max. Continuous Pump Speed	3000 rpm
Max. Limited Pump Speed	3500 rpm
Max. Continuous Pressure	600 bar
Max. Intermit. Peak Pressure	700 bar
Weight without inlet fitting	5,50 kg
Weight with inlet fitting	5,60 kg
Fluid	Min.B.Hyd.Oil
Inlet	G 1"
Outlet	G ¼"

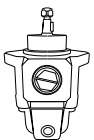

CW

Rotation :
Fixed-Clock Wise

12 cc

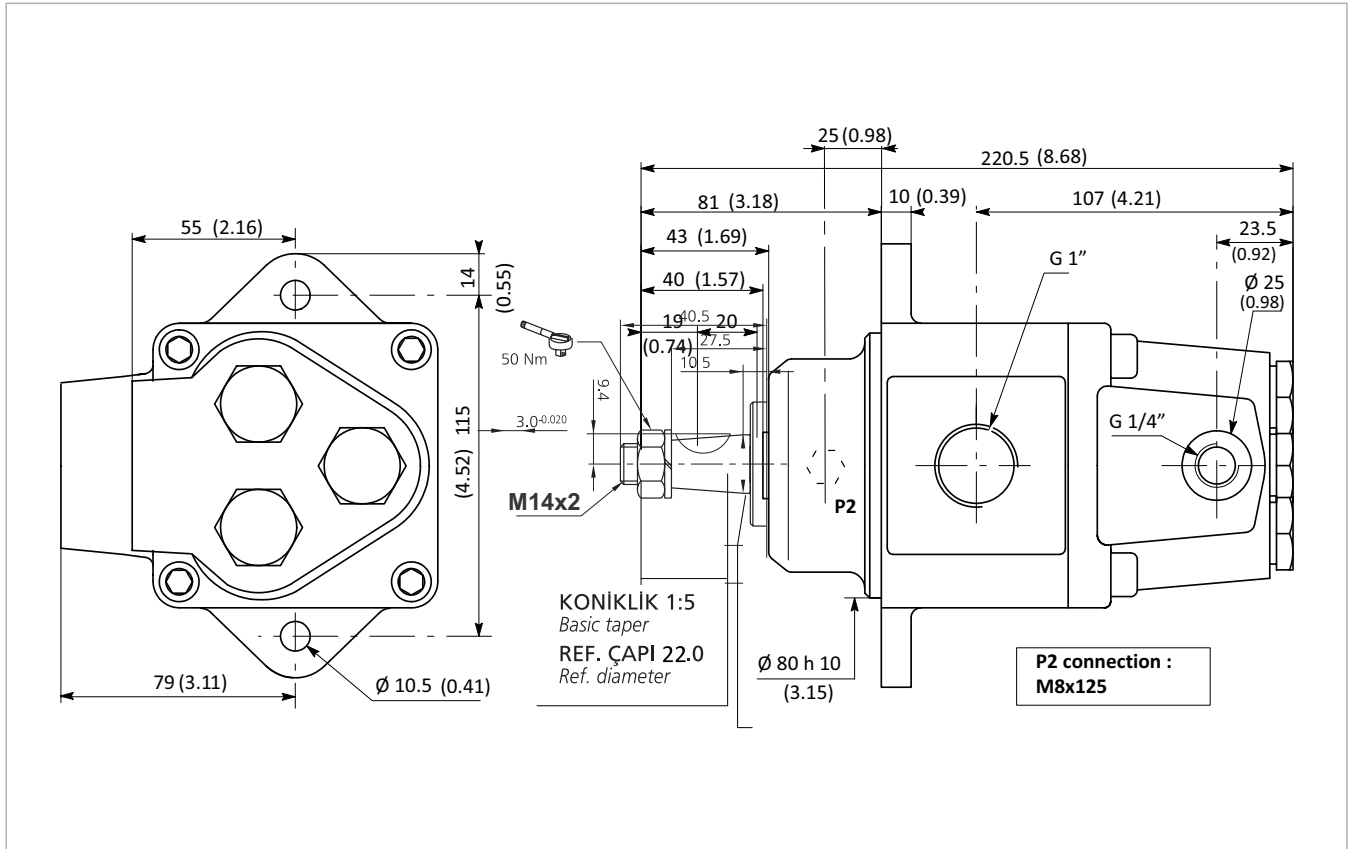

x 1000 rpm	7,80 cc
x 1500 rpm	11,70 cc
Max. Continuous Pump Speed	2800 rpm
Max. Limited Pump Speed	3000 rpm
Max. Continuous Pressure	450 bar
Max. Intermit. Peak Pressure	500 bar
Weight without inlet fitting	8,00 kg
Weight with inlet fitting	8,15 kg
Fluid	Min.B.Hyd.Oil
Inlet	G 1"
Outlet	G 1/4"



CW

Rotation :
Fixed-Clock Wise

15 cc

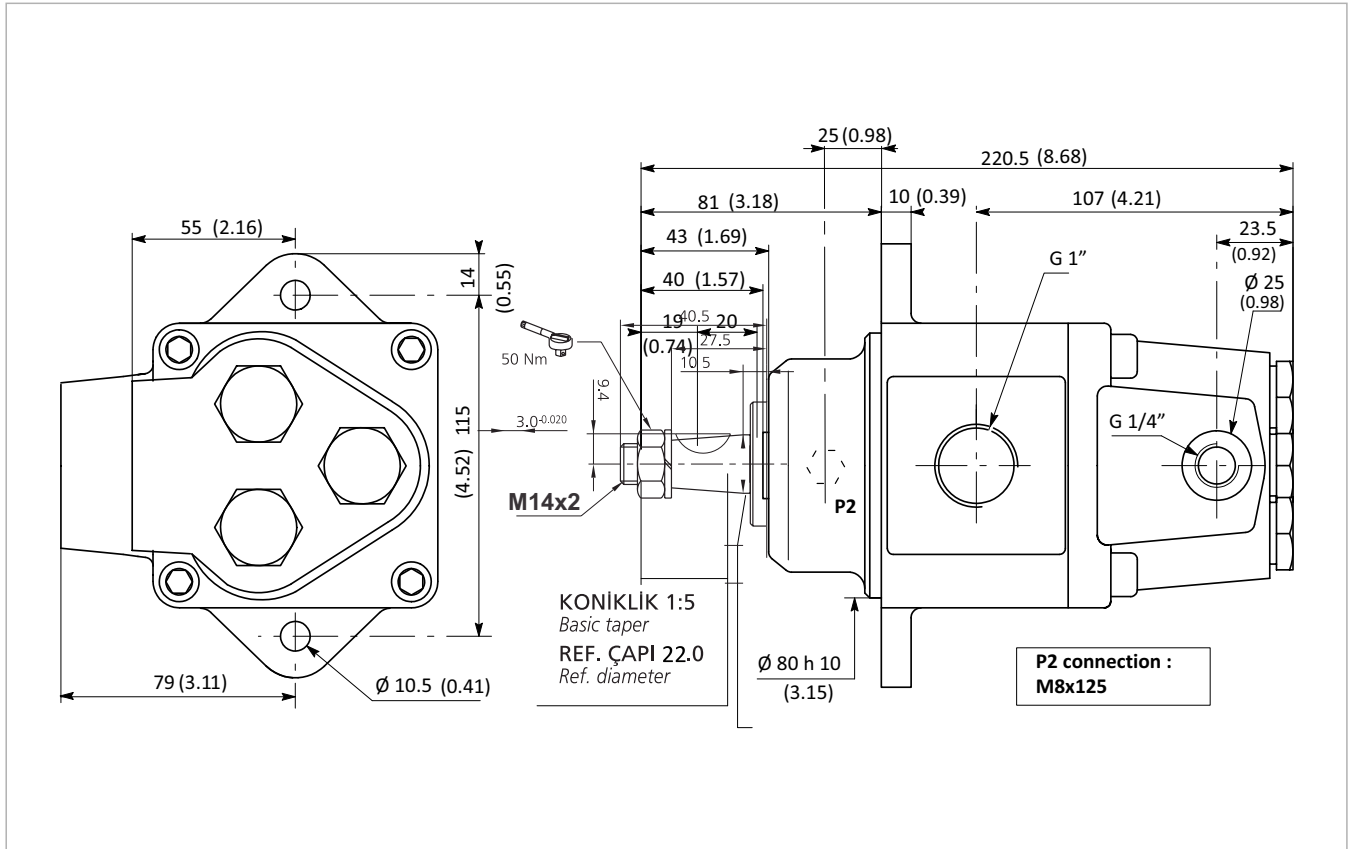

x 1000 rpm	10,50 cc
x 1500 rpm	15,75 cc
Max. Continuous Pump Speed	2800 rpm
Max. Limited Pump Speed	3000 rpm
Max. Continuous Pressure	400 bar
Max. Intermit. Peak Pressure	450 bar
Weight without inlet fitting	8,00 kg
Weight with inlet fitting	8,15 kg
Fluid	Min.B.Hyd.Oil
Inlet	G 1"
Outlet	G 1/4"



CW

Rotation :
Fixed-Clock Wise

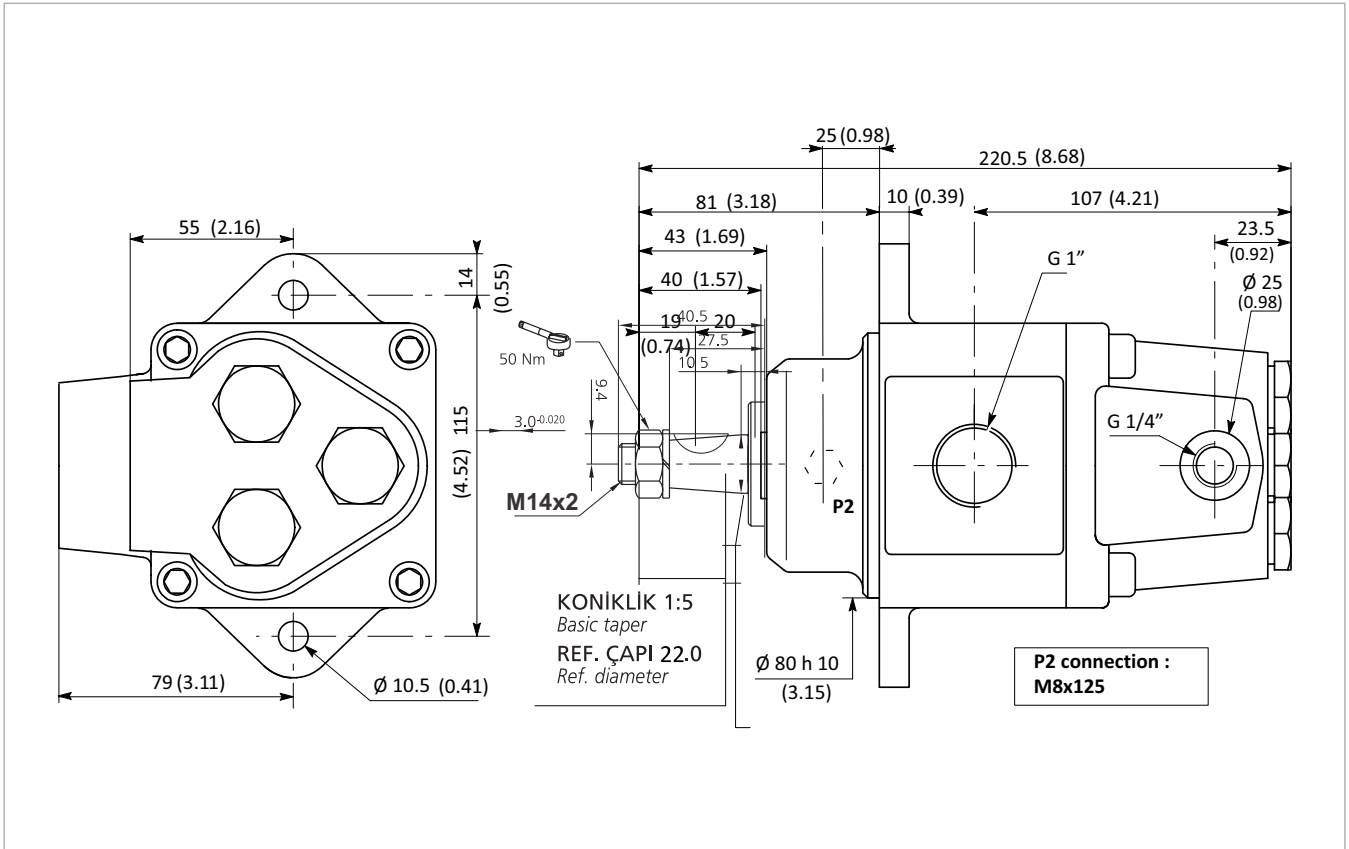

x 1000 rpm	14,73 cc
x 1500 rpm	22,09 cc
Max. Continuous Pump Speed	2800 rpm
Max. Limited Pump Speed	3000 rpm
Max. Continuous Pressure	400 bar
Max. Intermit. Peak Pressure	500 bar
Weight without inlet fitting	8,00 kg
Weight with inlet fitting	8,15 kg
Fluid	Min.B.Hyd.Oil
Inlet	G 1"
Outlet	G 1/4"

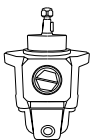

CW

Rotation :
Fixed-Clock Wise

35 cc

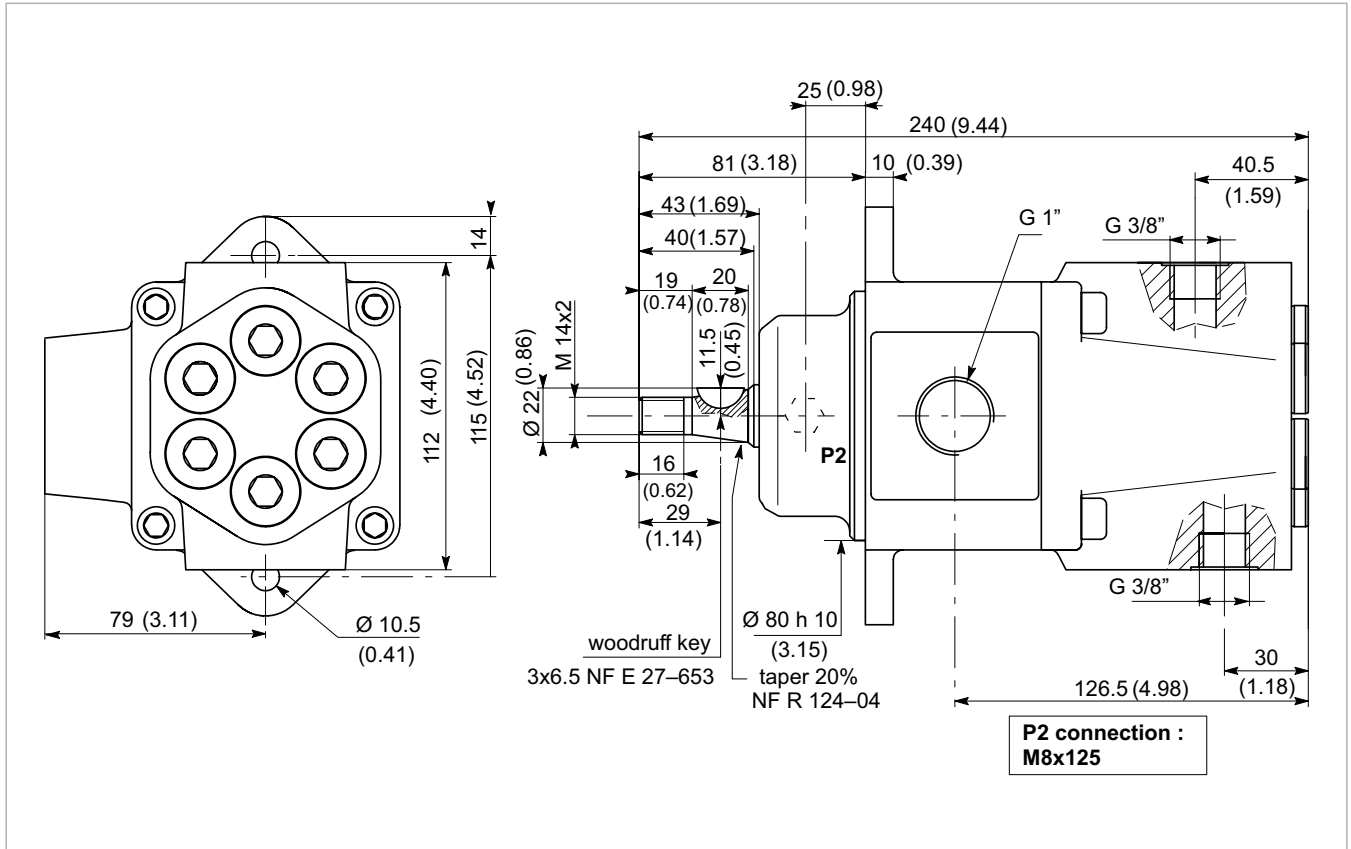

x 1000 rpm	23,70 cc
x 1500 rpm	35,55 cc
Max. Continuous Pump Speed	2500 rpm
Max. Limited Pump Speed	2800 rpm
Max. Continuous Pressure	400 bar
Max. Intermit. Peak Pressure	500 bar
Weight without inlet fitting	12,00 kg
Weight with inlet fitting	12,25 kg
Fluid	Min.B.Hyd.Oil
Inlet	47,8 _{mm}
Outlet	26,4 _{mm}

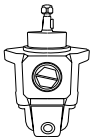

CW

Rotation :
Fixed-Clock Wise

45 cc

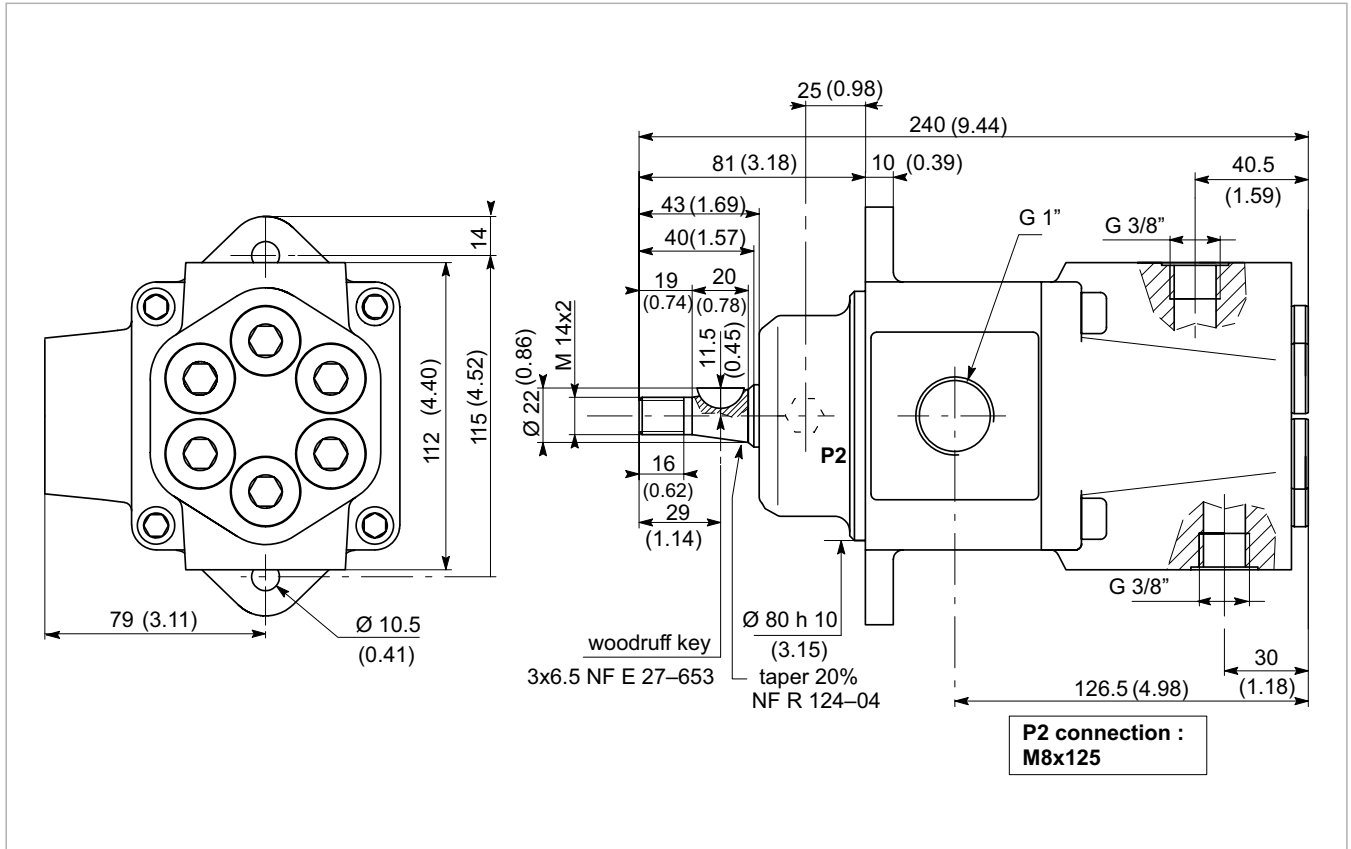

x 1000 rpm	30,40 cc
x 1500 rpm	45,60 cc
Max. Continuous Pump Speed	2400 rpm
Max. Limited Pump Speed	2700 rpm
Max. Continuous Pressure	400 bar
Max. Intermit. Peak Pressure	500 bar
Weight without inlet fitting	12,00 kg
Weight with inlet fitting	12,25 kg
Fluid	Min.B.Hyd.Oil
Inlet	47,8 _{mm}
Outlet	26,4 _{mm}

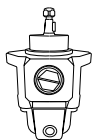

CW

Rotation :
Fixed-Clock Wise