

x 1000 rpm	x 1500 rpm	Max. Contin. Pump Speed	Max. Intermit. Pump Speed	Max. Contin. Pressure	Max. Peak Pressure	Torque bar	Torque at 350 bar	Max. Flow	Weight without accessor.	Weight with accessor.	Max. Motor Temp.	Min. Motor Temp.
25,00 cc	37,50 cc	6250 rpm	6800 rpm	400 bar	450 bar	0.40 m.N/bar	140 m.N	156	12,00 kg	12,50 kg	-25°	110°

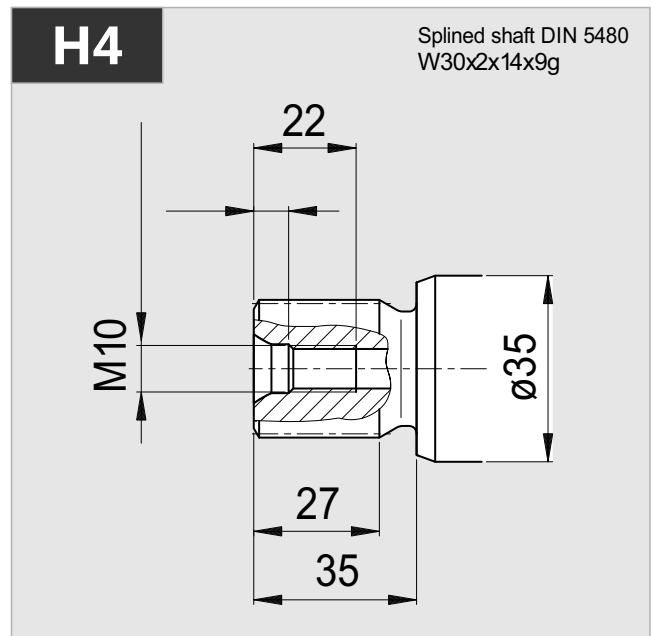

x 1000 rpm	x 1500 rpm	Max. Contin. Pump Speed	Max. Intermit. Pump Speed	Max. Contin. Pressure	Max. Peak Pressure	Torque bar	Torque at 350 bar	Max. Flow	Weight without accessor.	Weight with accessor.	Max. Motor Temp.	Min. Motor Temp.
32,00 cc	48,00 cc	6250 rpm	6800 rpm	400 bar	450 bar	0.51 m.N/bar	174 m.N	200	12,00 kg	12,50 kg	-25°	110°

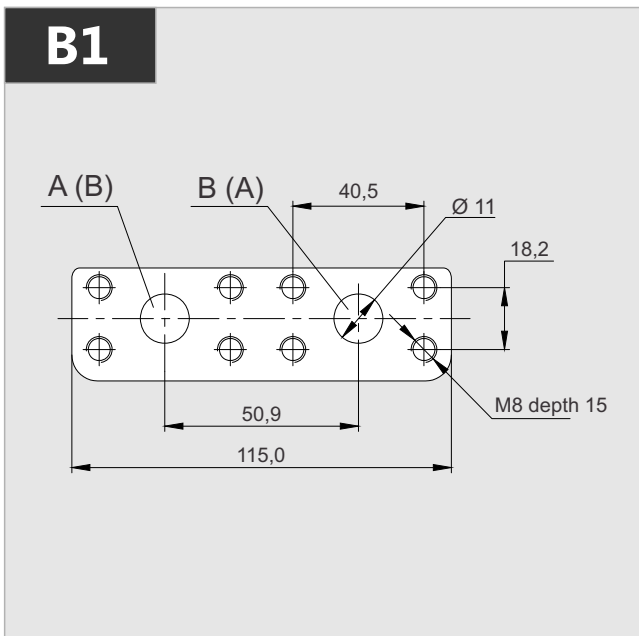
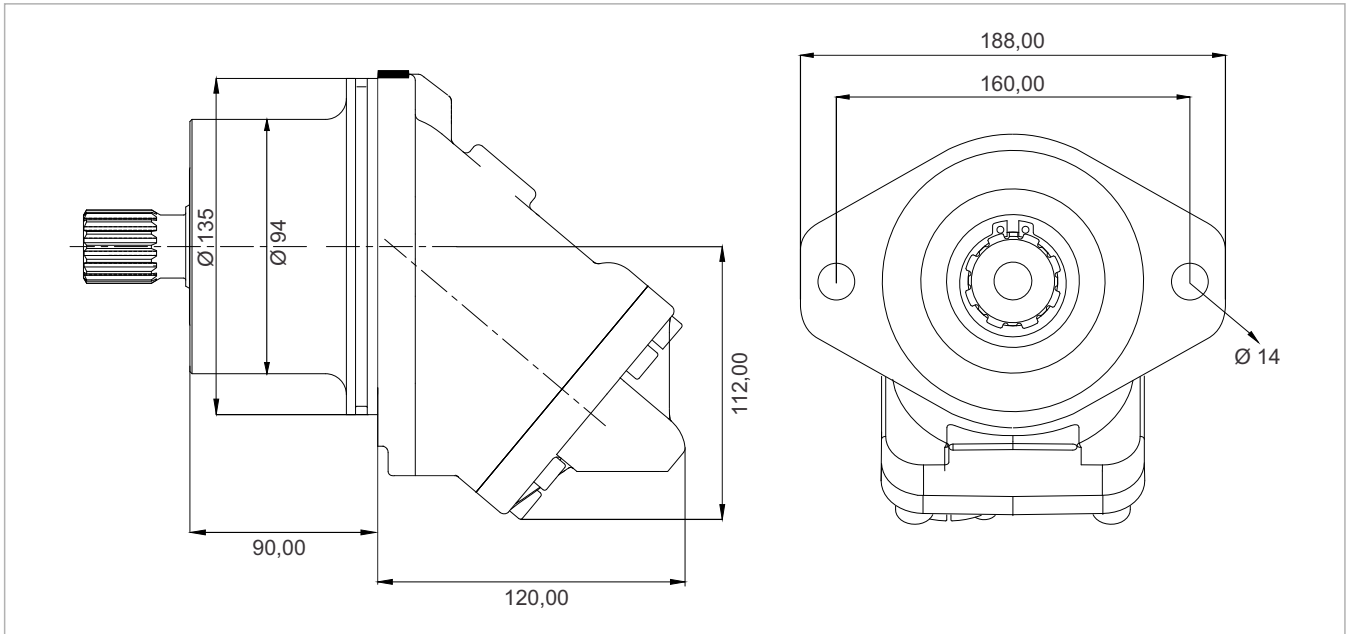
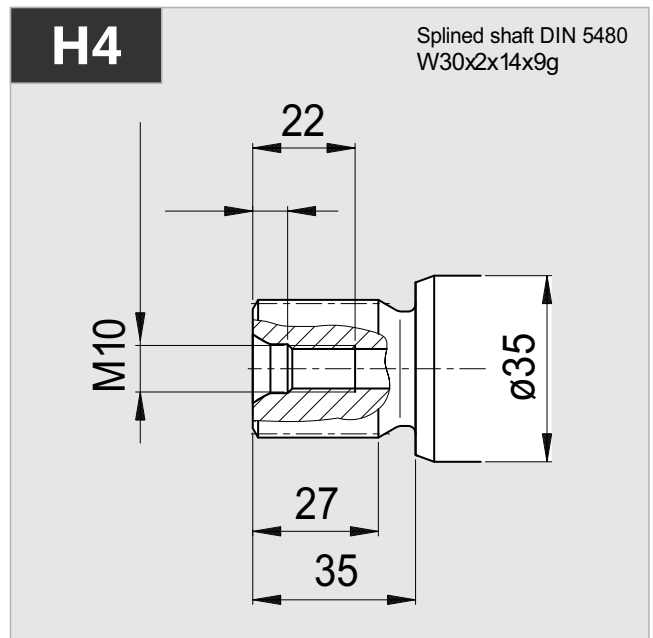
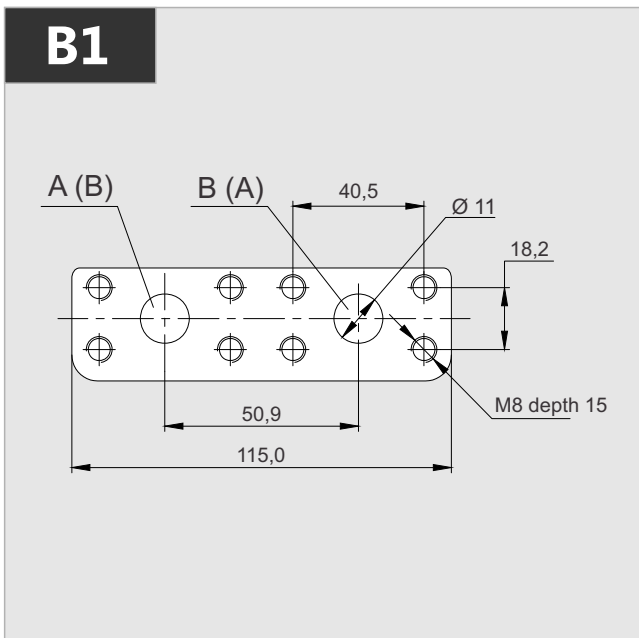
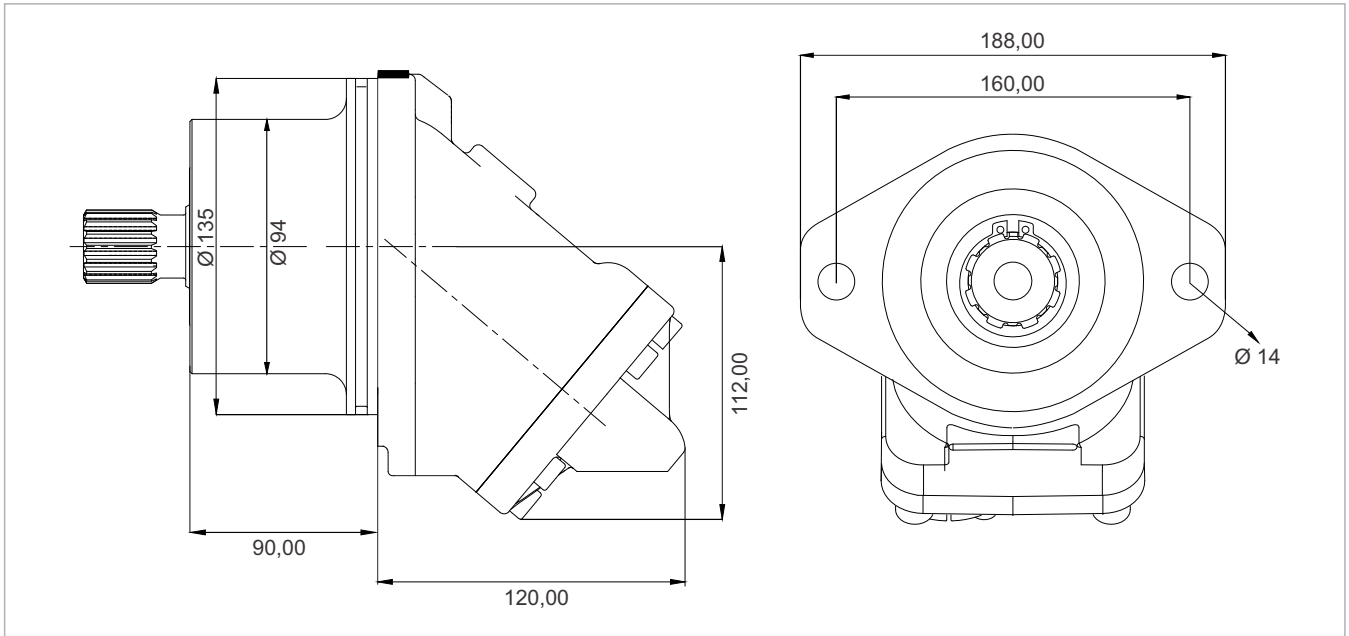

x 1000 rpm	x 1500 rpm	Max. Contin. Pump Speed	Max. Intermit. Pump Speed	Max. Contin. Pressure	Max. Peak Pressure	Torque bar	Torque at 350 bar	Max. Flow	Weight without accessor.	Weight with accessor.	Max. Motor Temp.	Min. Motor Temp.
40,20 cc	60,30 cc	5600 rpm	6300 rpm	400 bar	450 bar	0.68 m.N/bar	228 m.N	225	12,00 kg	12,50 kg	-25°	110°

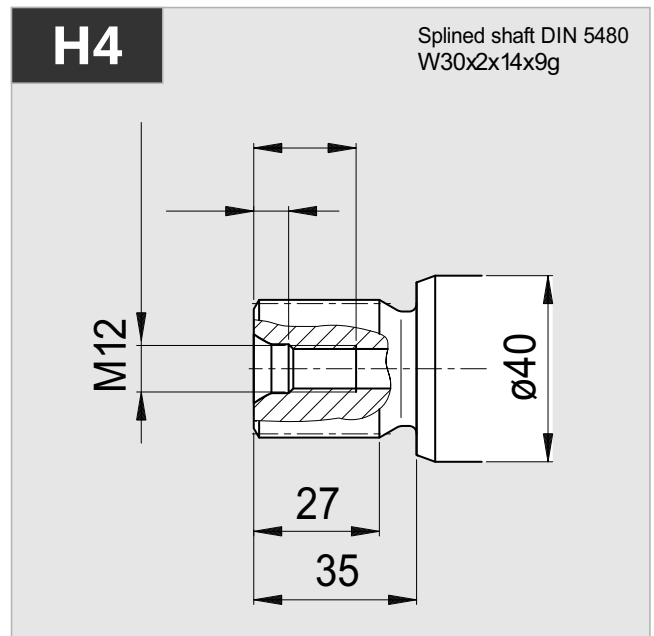
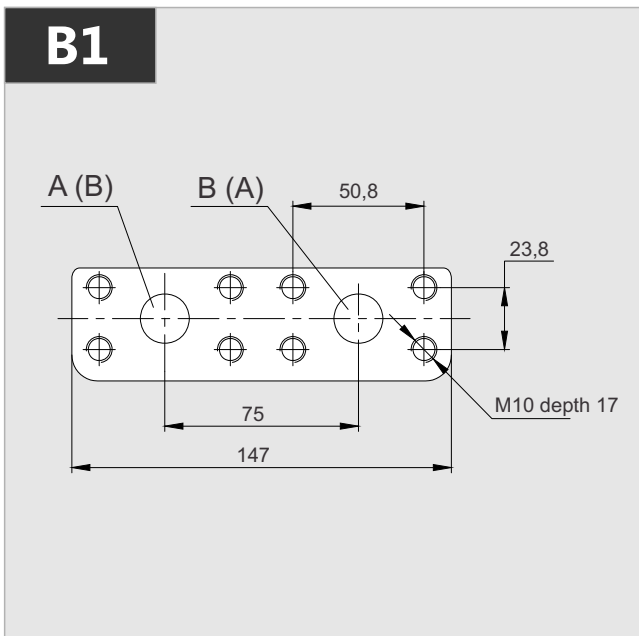
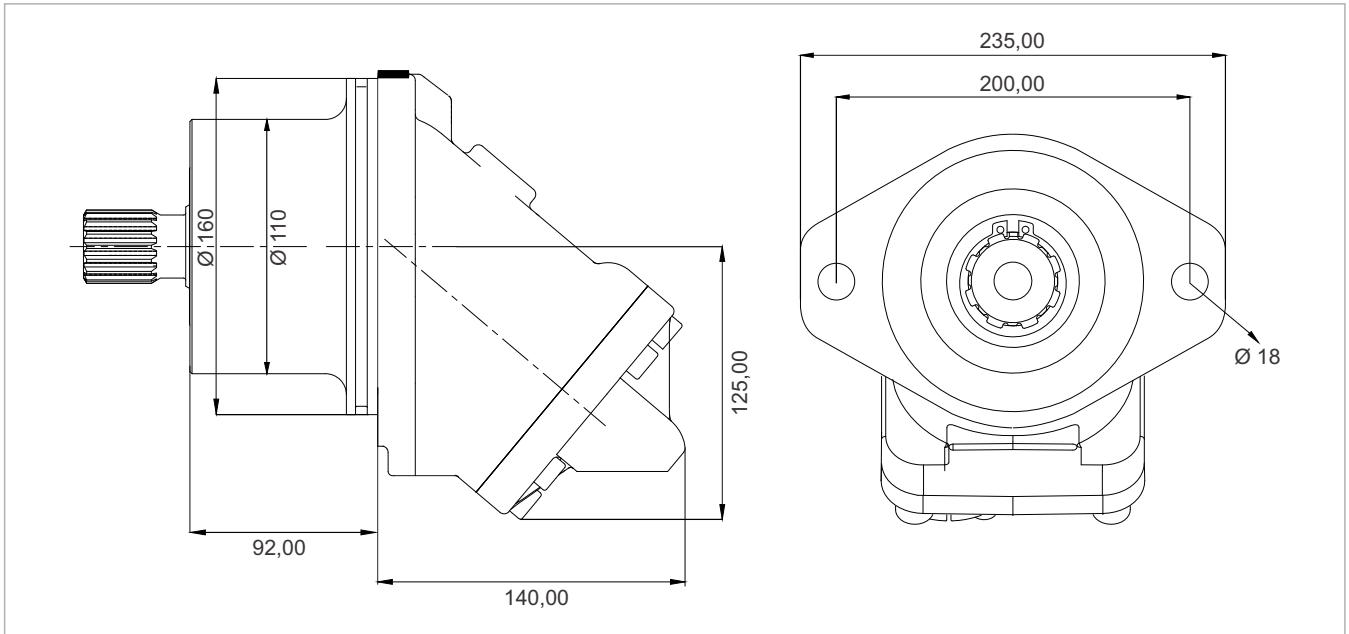

x 1000 rpm	x 1500 rpm	Max. Contin. Pump Speed	Max. Intermit. Pump Speed	Max. Contin. Pressure	Max. Peak Pressure	Torque bar	Torque at 350 bar	Max. Flow	Weight without accessor.	Weight with accessor.	Max. Motor Temp.	Min. Motor Temp.
50,00 cc	75,00 cc	5000 rpm	5500 rpm	400 bar	450 bar	0.80 m.N/bar	280 m.N	250	18,50 kg	19,00 kg	-25°	110°

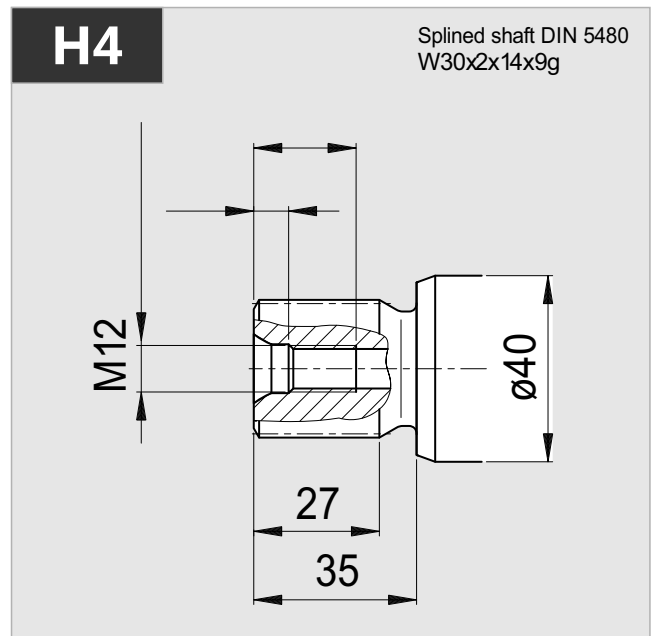
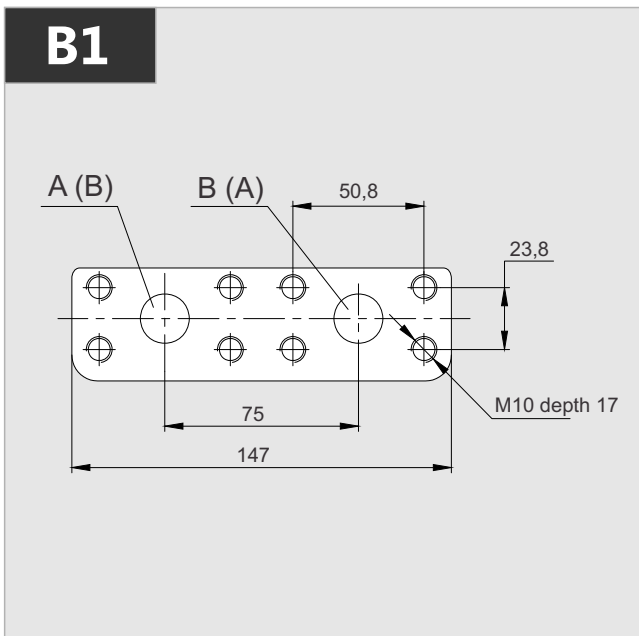
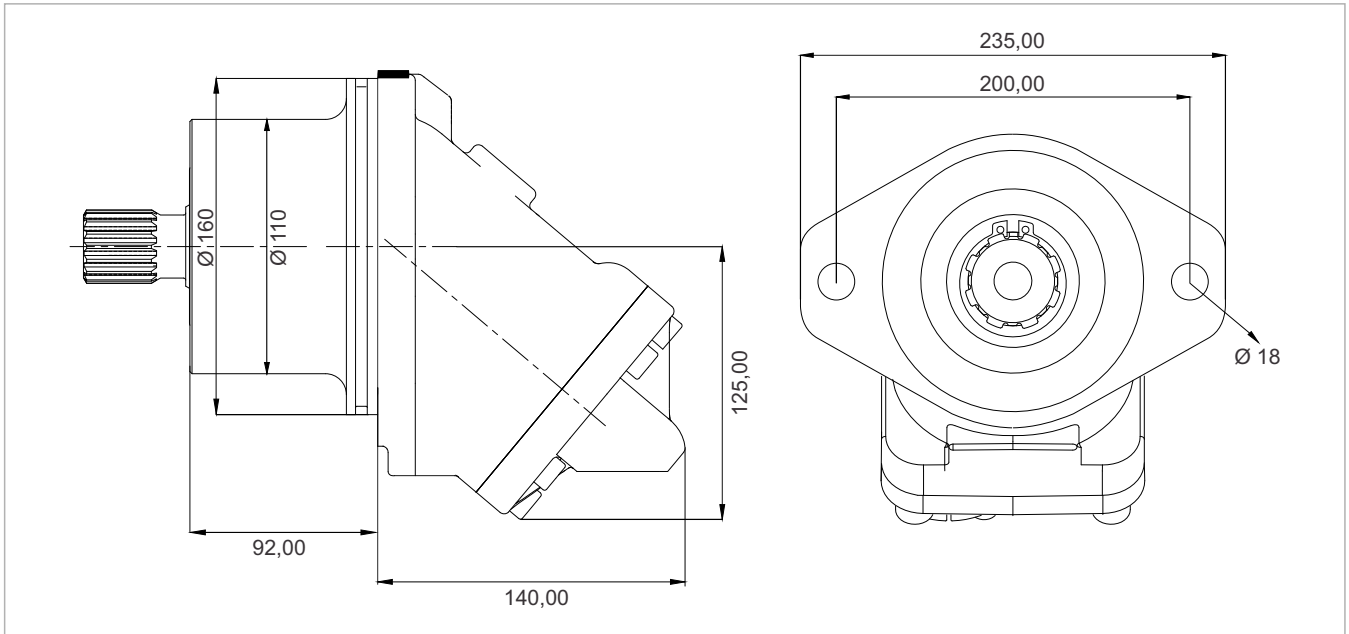

x 1000 rpm	x 1500 rpm	Max. Contin. Pump Speed	Max. Intermit. Pump Speed	Max. Contin. Pressure	Max. Peak Pressure	Torque bar	Torque at 350 bar	Max. Flow	Weight without accessor.	Weight with accessor.	Max. Motor Temp.	Min. Motor Temp.
56,40 cc	84,60 cc	5000 rpm	5500 rpm	400 bar	450 bar	0.92 m.N/bar	320 m.N	282	18,50 kg	19,00 kg	-25°	110°

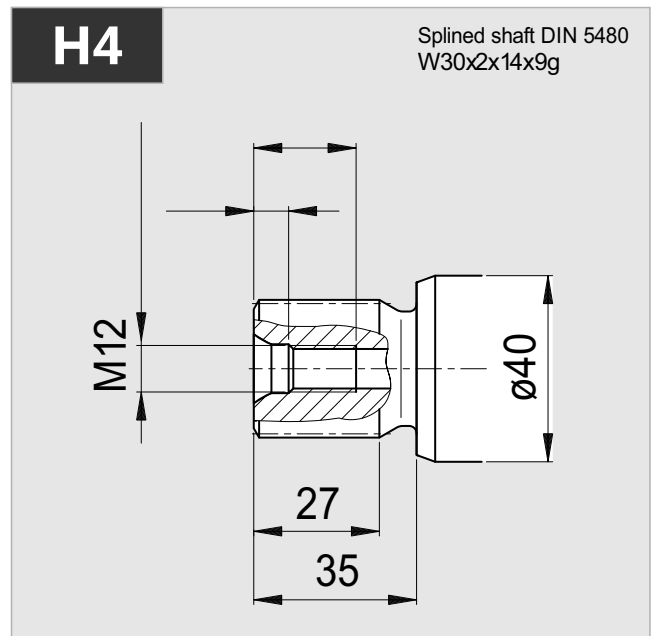
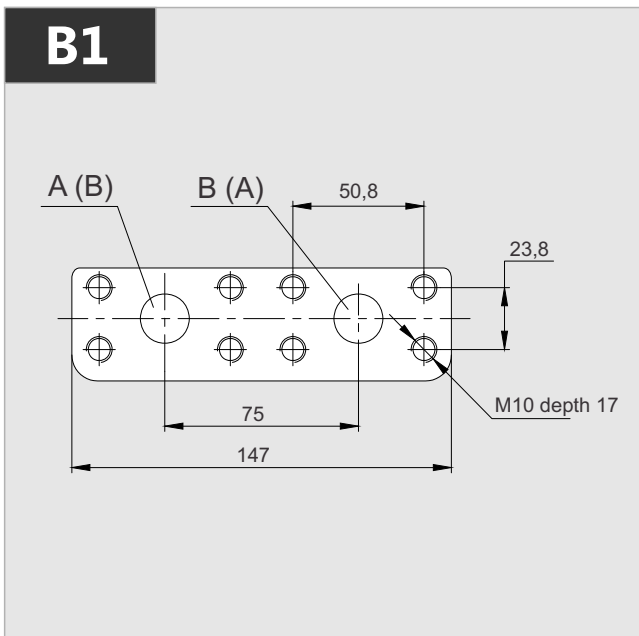
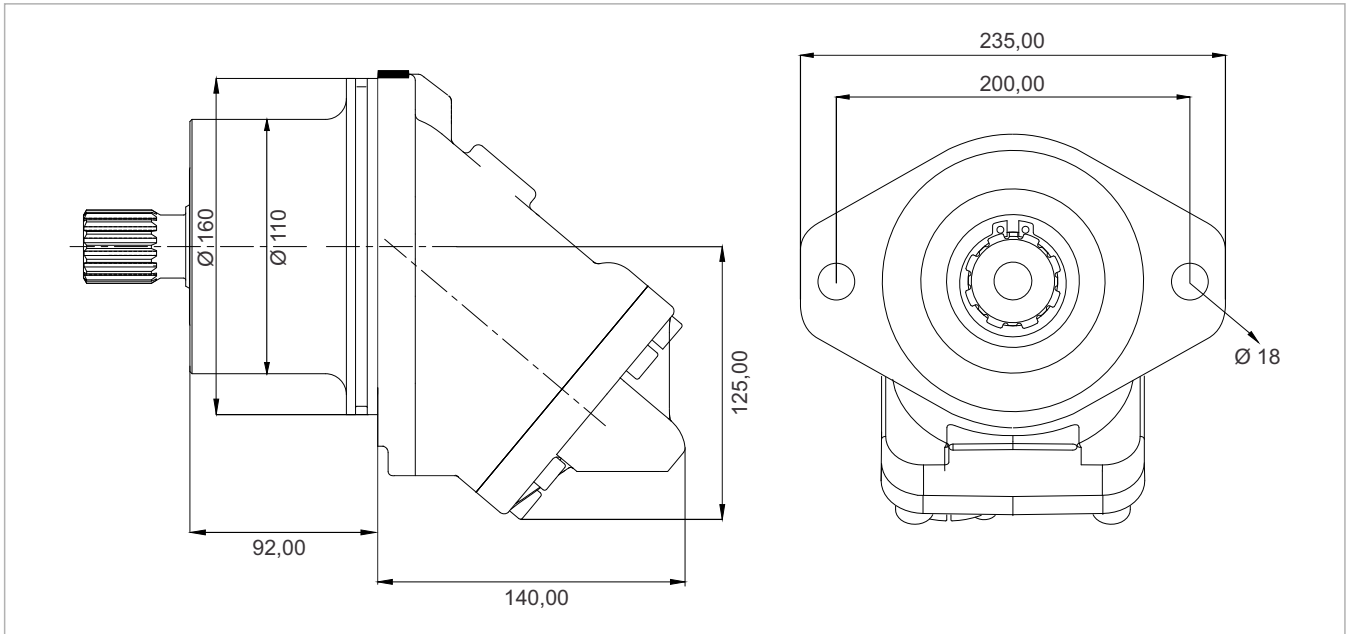

x 1000 rpm	x 1500 rpm	Max. Contin. Pump Speed	Max. Intermit. Pump Speed	Max. Contin. Pressure	Max. Peak Pressure	Torque bar	Torque at 350 bar	Max. Flow	Weight without accessor.	Weight with accessor.	Max. Motor Temp.	Min. Motor Temp.
63,00 cc	94,50 cc	5000 rpm	5500 rpm	400 bar	450 bar	1.00 m.N/bar	350 m.N	315	18,50 kg	19,00 kg	-25°	110°

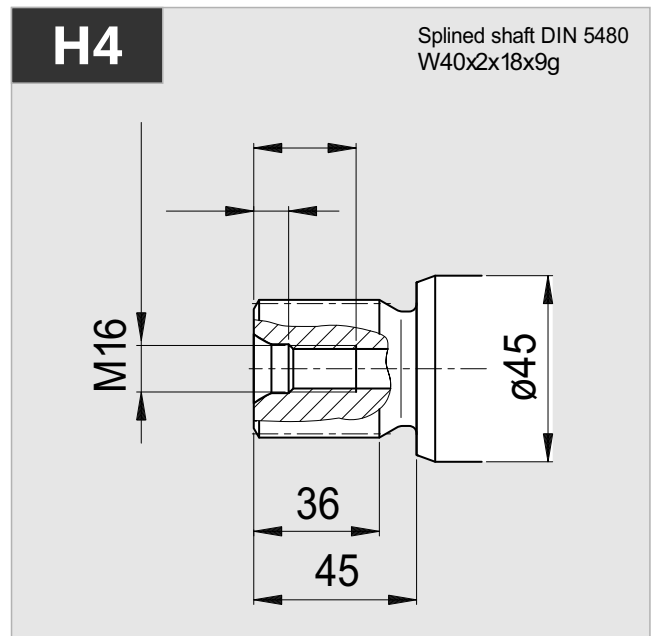
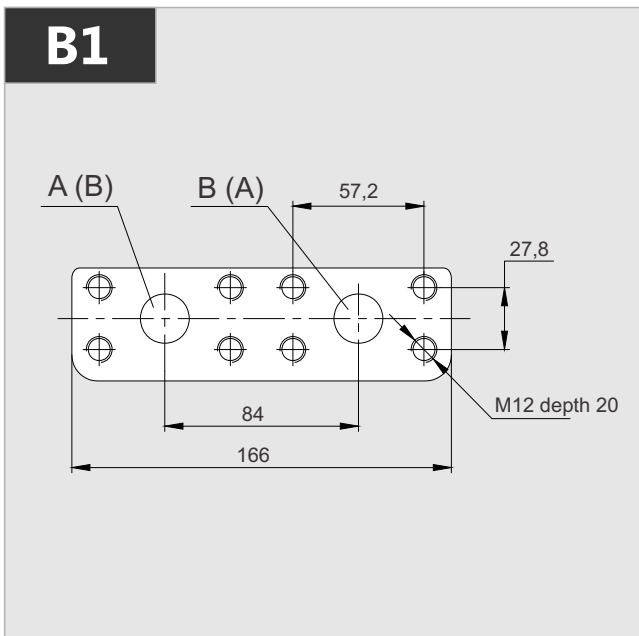
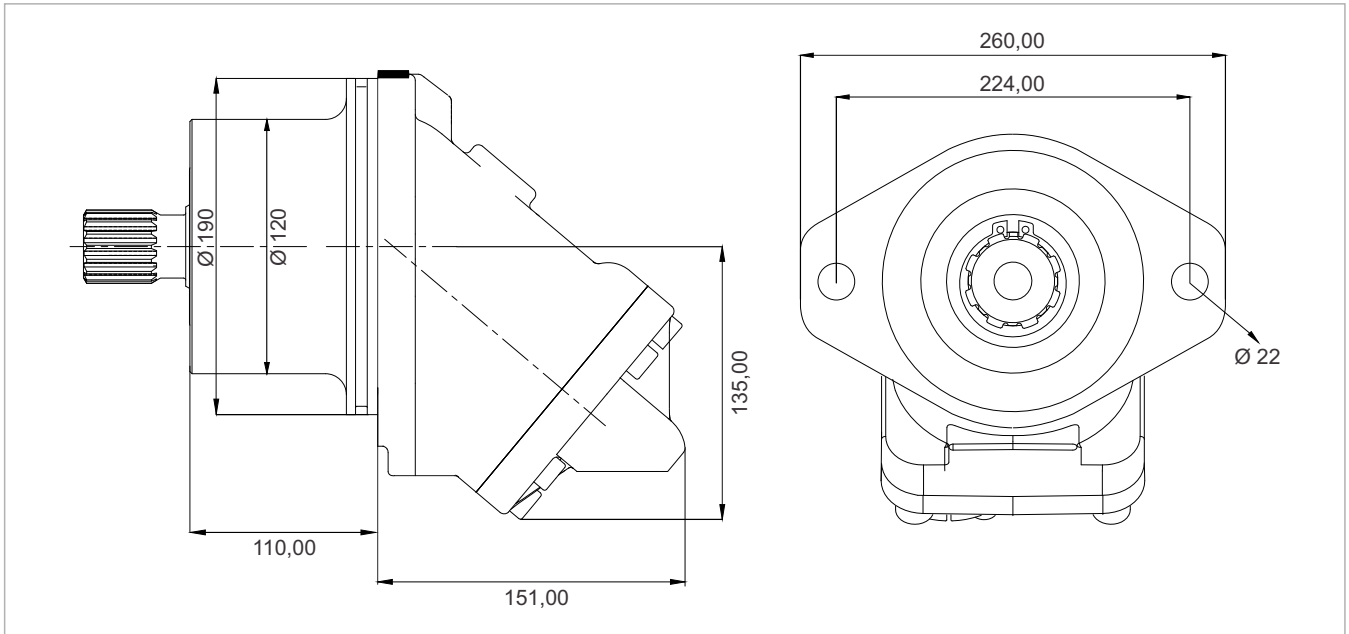

x 1000 rpm	x 1500 rpm	Max. Contin. Pump Speed	Max. Intermit. Pump Speed	Max. Contin. Pressure	Max. Peak Pressure	Torque bar	Torque at 350 bar	Max. Flow	Weight without accessor.	Weight with accessor.	Max. Motor Temp.	Min. Motor Temp.
80,00 cc	120,00 cc	4400 rpm	4900 rpm	400 bar	450 bar	1.28 m.N/bar	440 m.N	352	25,50 kg	26,00 kg	-25°	110°

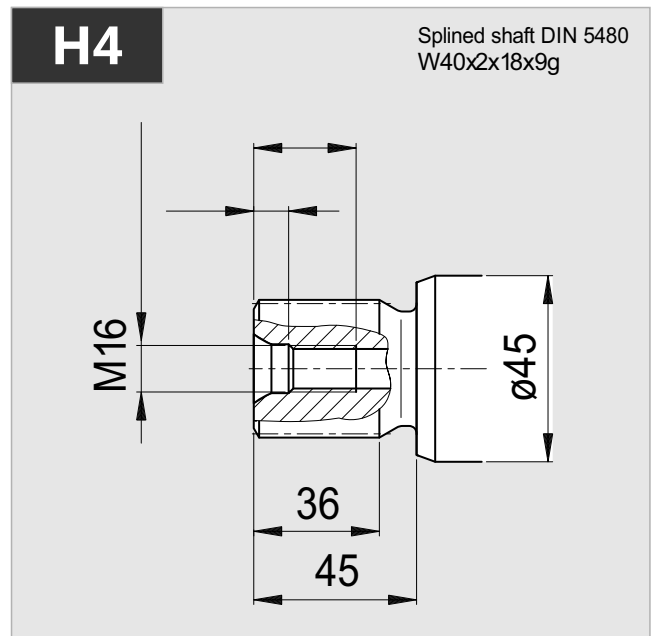
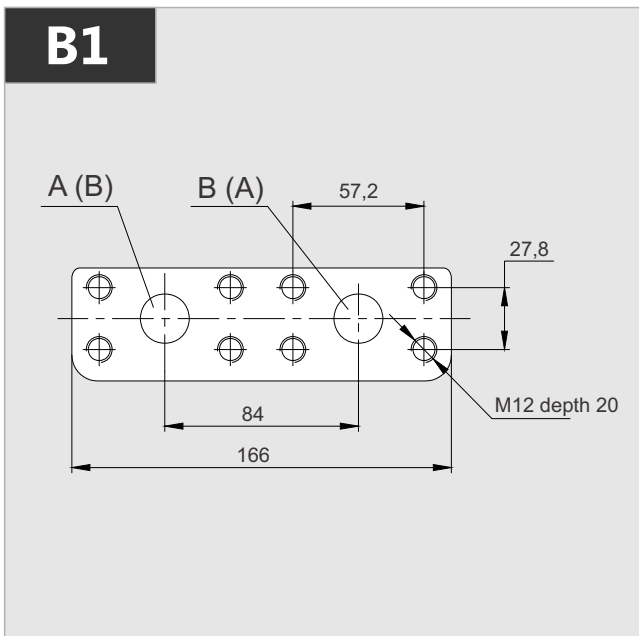
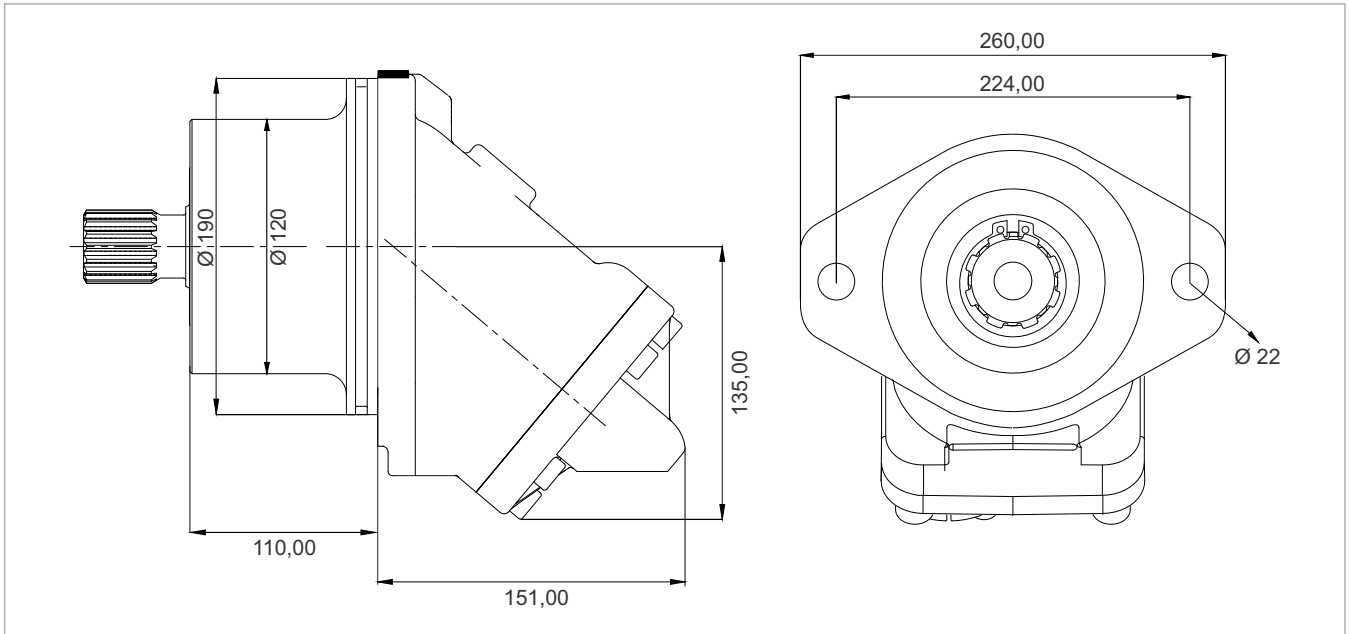

x 1000 rpm	x 1500 rpm	Max. Contin. Pump Speed	Max. Intermit. Pump Speed	Max. Contin. Pressure	Max. Peak Pressure	Torque bar	Torque at 350 bar	Max. Flow	Weight without accessor.	Weight with accessor.	Max. Motor Temp.	Min. Motor Temp.
108,4 cc	162,6 cc	4000 rpm	4400 rpm	400 bar	450 bar	1.69 m.N/bar	600 m.N	433	25,50 kg	26,00 kg	-25°	110°